

# E40 - Motor pumps

20 March 2012

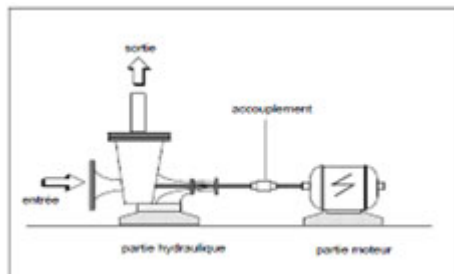

## 1) What is involved ?



### Centrifugal electric surface pump Source : ACF

These are pumps that operate continuously without human intervention and comprising the following three main parts :

- A motor that provides the necessary pumping power.
- A driveshaft that sends this power to the pump itself.
- A pump, the water handling part that uses this power to draw the water up from the well.

The power source is usually a thermal (gasoline or diesel) or electrical one.

**This factsheet essentially covers the pumps used to supply drinking water** but the same types of pumps are also used for irrigation.

## 2) Who use this means and since when ?

Motor pumps have been in regular use for decades now, essentially in urban areas where the demand for water cannot be met using hand pumps, but also in rural areas, especially for irrigation and emergency applications.

## 3) Why ?

Using motor pumps represents significant improvement over hand pumps, as :

- They do not have flow or supply height restrictions : There is always a pump available that is suited to

the needs in terms of flow rate and pressure.

- They can run continuously for hours at a time without any human presence and even 24/7 in major pumping stations, allowing them to produce far more water every day, so long as a tank with sufficient storage capacity is available.

- They do not require any physical effort and can quickly pump large amounts of water when necessary, unlike most hand pumps or solar or wind powered pumps.

#### 4) Who is primarily concerned ? Locations and contexts where this means appears best suited

Motor pumps allow pumping water with a chosen, more or less greater, flow rate, whether continuously or not. These pumps use petrol, diesel or electricity to power them and it is necessary for these resources to be easily available at a cost that is affordable to the local population to avoid issues involving shutdowns for lack of fuel or electric power.

Motor pumps should be used as soon as the necessary flow rate exceeds the capacity of manual pumps, i.e. approx. 1 to 2 cu. metres per hour. They are suitable for supplying major villages and urban or suburban areas with water. Rural areas use low power pumps rated at less than 4 KW or 5.5 HP, which corresponds to maximum flow rates of 30-50 cu. metres per hour depending on the force height.

#### 5) The two major categories of pumps

**Motor pumps** used to supply drinking water **can be placed in two major categories** depending on the water capture mode used :



**Surface pumps** (horizontal installations) : These are **suction pumps** that may be motor pumps when fitted with a petrol or diesel engine (the latter being the most frequent case in rural areas) or electric motor pumps when fitted with an electric motor. They are used for :

- Pumping water from a **shallow well** (with a suction height of less than 7 metres),
- Drawing water from a spring or water course,
- Feeding a network from a tank.

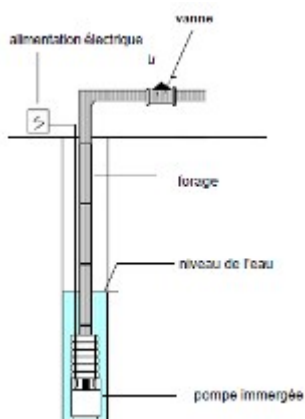

**Submersible pumps** (vertical installations) are used to **pump from down below** (deep wells or drillings). They are most often fitted with an electric motor. In the absence of any mains electric power, non submerged diesel powered pumps may be found using a drive shaft. These drive shafts are however fairly fragile and cannot be used for great depths. Another solution : Plan to install a standalone electric power source (electric generator, solar panels or windmills).

There are **many models** available in each of these categories. Some ten years ago, for example, there were already 25 of them in Burkina Faso.

## 6) What does this process involve ? How is it used ?

Motor driven pumps are centrifugal pumps from the turbo-pump family.

### a) Centrifugal pump operating principle

The fluid is sucked in axially, under the effect of the rotation of an impeller fitted with vanes or blades, and located in the pump casing where it accelerates radially before being forced out. The shaft is turned by an electric or thermal motor.

### b) Important parameters to be taken into account

**Before purchasing a pump** and so as to operate it under the best conditions and not risk damaging it, **always pay attention**, in addition to the pump's flow rate and total pressure height and motor power, **to the efficiency of the entire unit (pump + motor) and to the motor operating point without forgetting the Net Positive Suction Head or NPSH, all of which information should be provided by the vendors.**

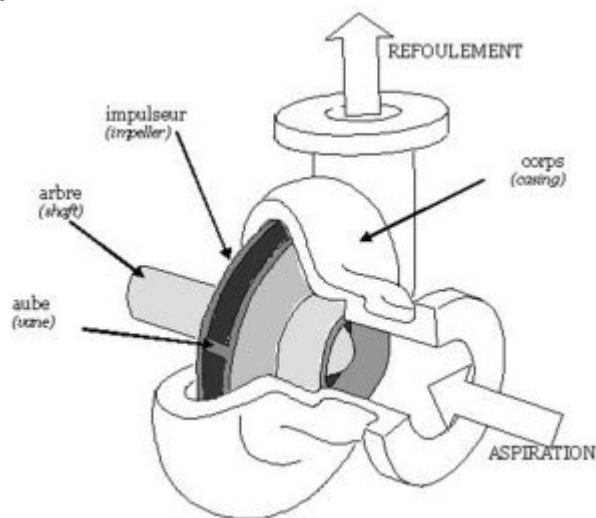

**Diagram of a centrifugal motor driven pump. Source : Wikipedia**

**Reliable vendors characterise their pumps on the basis of curves that you should ask for** and that provide the following data, on the basis of the different rated rotation speeds :

- The characteristic total manometric head figure based on flow :  $HMT=f(Q)$  for various wheel diameters depends on

- Power absorbed
- Efficiency
- Required NPSH

*Details on power calculations :*

**The power absorbed** on the pump shaft is given by the following formula (case with water, specific weight equals 1) :

$$P = Q \times HMT / 367 \times \eta$$

With :  $P$  : power in kw,  $1kw = 1.36 HP$ ,

$HMT$  : Total manometric head (m CE),  $Q$  : flow rate (cu. metres per hour),  $\eta$  : pump efficiency.

**The power consumed** equals power absorbed on the shaft over motor efficiency.

**The efficiency of the complete unit (pump + motor)** is the ratio between useful power (power applied to the fluid to achieve a certain flow rate at a given HMT) and the power consumed by the motor to achieve this flow rate with this HMT. It generally varies between 0.8 and 0.9.

**Choose the pump so that the operating point is as close as possible to the point where the efficiency is maximum as stated by the vendor.**

**As for NPSH**, this is a parameter that measures the difference between the pressure of the liquid at a given point and its saturating steam pressure. This parameter is **an important one to take into account** for if the liquid pressure falls below the saturating steam pressure, then the liquid will boil and this is very dangerous within a centrifugal pump as this will damage the pump body and reduce the efficiency.

**The available NPSH shown by the vendor must always exceed the required NPSH.**

**It is therefore essential to properly take into account all of the characteristics** stated by the vendor before choosing a pump. **It may be more advantageous to purchase a pump that is a little more expensive if it offers improved efficiency.**

## **7) Main advantages and drawbacks**

The main advantage of motor pumps is to avoid the need for any continuous human presence and to **eliminate the physical effort** required to actuate a hand pump. Specifically, an electric pumping system with an open air or pressurised tank allows fully automated operation controlled by level or pressure sensors.

**Motor pumps are easy to use.**

It is however necessary to reprime centrifugal suction pumps (surface ones) every time they are used for when the pump stops, the liquid in it runs back by gravity feed into the well. This can however be avoided by installing an extra mechanism. Motor suction pumps, just like hand suction pumps, are further limited to a suction height of seven metres.

Submerged pumps do not face these drawbacks.

Given their low efficiency, petrol powered pumps are only used for small installations that operate only for short periods (around one hundred hours per year. Generally electric or diesel powered pumps are preferable).

Motor pumps of whatever kind must be properly maintained. In addition to the actual pump maintenance (please refer to the factsheet on maintaining hand pumps) there is the motor maintenance.

When well maintained and if wearing parts are replaced regularly, then motor pumps can have a relatively long service life.

Ensure that they are not oversized, for as is sometimes observed, this will lower their efficiency and prematurely wear them out.

**Their main drawback is their operating cost** as explained in the next section.

## **8) Costs (Purchasing + Maintenance)**

The excess cost of a motor pump in relation to a hand pump depends on motor characteristics. For example, the price of a motor depends on the motor's rotation speed : The slower it is, the more expensive the pump. On the other hand, reducing motor speed will reduce noise, improve the suction capacity and reduce pump wear.

Low power pump price indications are as follows :

- 1.5 HP motor pumps : 150 to 200 Euros
- 4 HP motor pumps : 350 to 400 Euros
- 1 KW submersible electric pumps : approx. 500 Euros
- 1 to 3 KW submersible electric pumps : 500 to 1,000 Euros

High capacity pumps are made on demand.

Although the purchase price of **low power pumps** is not very high, **running them is costly**. This is mainly due to the price of the electricity or fuel used to power them which is tending to increase sharply. Diesel fuel usage varies with running conditions (operating speed). For a 1.5 HP pump, 0.30 to 0.5 litres of diesel are required. Running costs also include lubricants, spare parts and repairs.

A motor pump's service life depends on its annual usage and on maintenance. It is therefore more relevant to speak in operating hours. Its service life is some 2,500 to 5,000 hours. In practice, renewal takes place after two to five years in service. An electric pump has a longer service life.

Before purchasing a motor pump, always ensure that it is not oversized, that its running costs are not prohibitive and that users are ready to pay the cost for fear of seeing the pump stop operating for lack of money to pay for fuel or electricity.

## 9) Where to obtain further information - Bibliography

- **Wikipedia** “**Centrifugal pump**”. Available [online] from :

[http://fr.wikipedia.org/wiki/Pompe\\_...](http://fr.wikipedia.org/wiki/Pompe_...)

- **GLS. Memotec No. 33** - “**Caractéristiques des pompes centrifuges**” (Centrifugal pump characteristics). Available [online] from :

<http://brochure.luisid.com/WaterTre...>

- **GLS. Memotec No. 34** - “**Critères de choix des pompes centrifuges**” (Centrifugal pump choice criteria). Available [online] from :

<http://brochure.luisid.com/WaterTre...>

- **GLS. Memotec No. 36** - “**Équipement à l’aspiration et au refoulement des pompes centrifuges**” (Equipment on the suction and outlet side of centrifugal pumps). Available [online] from :

<http://brochure.luisid.com/WaterTre...>

- **Practica Foundation**. “**Small scale irrigation**”. Available [online] from :

<http://www.practica.org/wp-content/...>

- **Mecaflux**. “**Pump and calculating the operating point**”. Available [online] from :

<http://www.mecaflux.com/pompes.htm>

- **BRGM**. “**Les moyens d’exhaure pour puits et forages d’eau - 83 SGN 468 EAU**” (Ways of draining wells and water drillings). (Not available on line)

- Emplacement : Accueil > en > Wikiwater > Technical sheet > Facilitating access to water > Distributing >
- Adresse de cet article : <https://wikiwater.fr/E40-Motor-pumps>